

Installation Note

Receiver Attenuators Upgrade Kit

For E8363B and E8364B PNA Series Microwave Network Analyzers

Network Analyzer Model Number	Upgrade Kit Part Number
E8363B and E8364B	E8364-60104



Agilent Technologies

Agilent Part Number: E8364-90020

Printed in USA January 2003

© Copyright 2003 Agilent Technologies, Inc. All rights reserved.



E8364-90020

Notice

THE MATERIAL CONTAINED IN THIS DOCUMENT IS PROVIDED “AS IS,” AND IS SUBJECT TO BEING CHANGED, WITHOUT NOTICE, IN FUTURE EDITIONS. FURTHER, TO THE MAXIMUM EXTENT PERMITTED BY APPLICABLE LAW, AGILENT DISCLAIMS ALL WARRANTIES, EITHER EXPRESS OR IMPLIED WITH REGARD TO THIS MANUAL AND ANY INFORMATION CONTAINED HEREIN, INCLUDING BUT NOT LIMITED TO THE IMPLIED WARRANTIES OF MERCHANTABILITY AND FITNESS FOR A PARTICULAR PURPOSE. AGILENT SHALL NOT BE LIABLE FOR ERRORS OR FOR INCIDENTAL OR CONSEQUENTIAL DAMAGES IN CONNECTION WITH THE FURNISHING, USE, OR PERFORMANCE OF THIS DOCUMENT OR ANY INFORMATION CONTAINED HEREIN. SHOULD AGILENT AND THE USER HAVE A SEPARATE WRITTEN AGREEMENT WITH WARRANTY TERMS COVERING THE MATERIAL IN THIS DOCUMENT THAT CONFLICT WITH THESE TERMS, THE WARRANTY TERMS IN THE SEPARATE AGREEMENT WILL CONTROL.

Getting Assistance from Agilent

By internet, phone, or fax, get assistance with all your test and measurement needs.

Online assistance: www.agilent.com/find/assist		
United States <i>(tel)</i> 1 800 452 4844	Latin America <i>(tel)</i> (305) 269 7500 <i>(fax)</i> (305) 269 7599	Canada <i>(tel)</i> 1 877 894 4414 <i>(fax)</i> (905) 282-6495
Europe <i>(tel)</i> (+31) 20 547 2323 <i>(fax)</i> (+31) 20 547 2390	Australia <i>(tel)</i> 1 800 629 485 <i>(fax)</i> (+61) 3 9210 5947	New Zealand <i>(tel)</i> 0 800 738 378 <i>(fax)</i> (+64) 4 495 8950
Japan <i>(tel)</i> (+81) 426 56 7832 <i>(fax)</i> (+81) 426 56 7840	Singapore <i>(tel)</i> 1 800 375 8100 <i>(fax)</i> (65) 836 0252	Malaysia <i>(tel)</i> 1 800 828 848 <i>(fax)</i> 1 800 801 664
India <i>(tel)</i> 1 600 11 2929 <i>(fax)</i> 000 800 650 1101	Hong Kong <i>(tel)</i> 800 930 871 <i>(fax)</i> (852) 2506 9233	Taiwan <i>(tel)</i> 0800 047 866 <i>(fax)</i> (886) 2 25456723
Philippines <i>(tel)</i> (632) 8426802 <i>(tel)</i> (PLDT subscriber only) 1 800 16510170 <i>(fax)</i> (632) 8426809 <i>(fax)</i> (PLDT subscriber only) 1 800 16510288	Thailand <i>(tel)</i> (outside Bangkok) (088) 226 008 <i>(tel)</i> (within Bangkok) (662) 661 3999 <i>(fax)</i> (66) 1 661 3714	People’s Republic of China <i>(tel)</i> (preferred) 800 810 0189 <i>(tel)</i> (alternate) 10800 650 0021 <i>(fax)</i> 10800 650 0121

About Installing the Upgrade Kit

Products affected.	E8363/4B; without Option 014 E8363/4B; Option 014 (without Option 081) E8363/4B; Option 014 and 081
Installation to be performed by	Agilent service center or personnel qualified by Agilent
Estimated installation time	1 hour
Estimated verification time	5 minutes

Description of Option 016 Receiver Attenuators

This option adds a 35-dB step attenuator in the channel A and channel B signal paths.

Items Included in the Upgrade Kit

Check the contents of your kit against this list. If any item is missing or damaged, contact Agilent Technologies. Refer to [“Getting Assistance from Agilent”](#) on page 2.

Table 1 Contents of Option 016 Upgrade Kit (E8364-60104)

Ref. Desig.	Description	Qty	Part Number
These parts are for all analyzers			
	Installation note (this document)	1	E8364-90020
	Machine screw, M3.0 x 8 CWPNTX (for attaching attenuators)	4	0515-0372
	Cable clamp	1	1400-1439
A43, A44	35-dB step attenuator	2	33325-60011
	Ribbon cable (for A43 and A44 step attenuators)	2	8121-0819
W47	RF cable, A43 channel A step attenuator to A27 channel A mixer	1	E8364-20131
W48	RF cable, A44 channel B step attenuator to A30 channel B mixer	1	E8364-20132
These parts are for analyzers with Option UNL but WITHOUT Option 014			
W7	RF cable, channel R1 attenuator to A28 channel R1 mixer	1	E8364-20149
W8	RF cable, channel R2 attenuator to A29 channel R2 mixer	1	E8364-20150
W45	RF cable, A25 test port 1 coupler to A43 channel A step attenuator	1	E8364-20147
W46	RF cable, A26 test port 2 coupler to A44 channel B step attenuator	1	E8364-20148
These parts are for analyzers WITH Options UNL and 014 but WITHOUT Option 081			
	Lower front panel overlay (Option UNL/016)	1	E8364-80024
W49	RF cable, PORT 1 RCVR A IN to A43 channel A step attenuator	1	E8364-20129
W50	RF cable, PORT 2 RCVR B IN to A44 channel B step attenuator	1	E8364-20130
W70	RF cable, REFERENCE 1 RCVR R1 IN to A28 channel R1 mixer	1	E8364-20151
W71	RF cable, REFERENCE 2 RCVR R2 IN to A29 channel R2 mixer	1	E8364-20126
These parts are for analyzers WITH Options UNL, 014, AND Option 081			
	Lower front panel overlay (Option UNL/014/016)	1	E8364-80024
W49	RF cable, PORT 1 RCVR A IN to A43 channel A step attenuator	1	E8364-20129
W50	RF cable, PORT 2 RCVR B IN to A44 channel B step attenuator	1	E8364-20130
W99	RF cable, A45 reference switch to A28 channel R1 mixer	1	E8364-20125
W71	RF cable, REFERENCE 2 RCVR R2 IN to A29 channel R2 mixer	1	E8364-20126

Installation Procedure for the Upgrade Kit

The network analyzer must be in proper working condition prior to installing this option. Any necessary repairs must be made before proceeding with this installation.

WARNING **This installation requires the removal of the analyzer's protective outer covers. The analyzer must be powered down and disconnected from the mains supply before performing this procedure.**

Electrostatic Discharge Protection

Protection against electrostatic discharge (ESD) is essential while removing or connecting cables or assemblies within the network analyzer.

Static electricity can build up on your body and can easily damage sensitive internal circuit elements when discharged. Static discharges too small to be felt can cause permanent damage. To prevent damage to the instrument:

- *always* wear a grounded wrist strap having a 1 M Ω resistor in series with it when handling components and assemblies.
- *always* use a grounded, conductive table mat while working on the instrument.
- *always* wear a heel strap when working in an area with a conductive floor. If you are uncertain about the conductivity of your floor, wear a heel strap.

Figure 1 shows a typical ESD protection setup using a grounded mat and wrist strap. Refer to “Tools and Equipment Required for the Installation” on page 6 for part numbers.

Figure 1 **ESD Protection Setup**

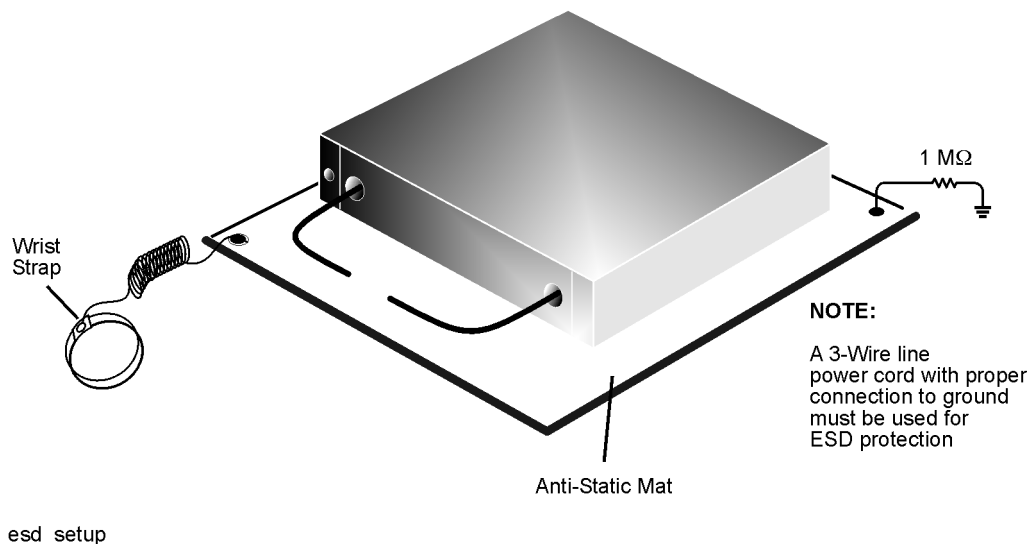

Overview of the Installation Procedure

Step 1. Remove the Outer Cover.

Step 2. Remove the Front Panel Assembly (Option 014 Only).

Step 3. Raise the Receiver Deck.

Step 4. Remove the Existing Cables.

Step 5. Install the Attenuators.

Step 6. Install the Option 016 Cables.

Step 7. Lower and Fasten the Receiver Deck.

Step 8. Replace the Lower Front Panel Overlay (Option 014 Only).

Step 9. Reinstall the Front Panel Assembly and Front Panel Jumpers (Option 014 Only).

Step 10. Reinstall the Outer Cover.

Step 11. Enable Option 016.

Step 12. Verify that Option 016 Is Enabled.

Tools and Equipment Required for the Installation

Description	Qty	Part Number
T-10 TORX driver (set to 9 in-lbs)	1	N/A
T-20 TORX driver (set to 21 in-lbs)	1	N/A
5/16-inch torque wrench (set to 10 in-lbs)	1	N/A
5/16-inch torque wrench (set to 21 in-lbs) (Option 014 only)	1	N/A
ESD grounding wrist strap	1	9300-1367
5-ft grounding cord for wrist strap	1	9300-0980
2 x 4 ft conductive table mat and 15-ft grounding wire	1	9300-0797
ESD heel strap (for use with conductive floors)	1	9300-1308

CAUTION Use a 5/16-inch torque wrench set to 10 in-lbs on all cable connections except the front-panel connectors to which the front-panel jumpers attach (Option 014). Use a 5/16-inch torque wrench set to 21 in-lbs for these connections.

Step 1. Remove the Outer Cover

CAUTION This procedure is best performed with the analyzer resting on its front handles in the vertical position. *Do not place the analyzer on its front panel without the handles.* This will damage the front panel assemblies.

Refer to [Figure 2](#) for this procedure.

1. Disconnect the power cord (if it has not already been disconnected).
2. With a T-20 TORX driver, remove the strap handles (item ①) by loosening the screws (item ②) on both ends until the handle is free of the analyzer.
3. With a T-20 TORX driver, remove the four rear panel feet (item ③) by removing the center screws (item ④).
4. Slide the four bottom feet (item ⑤) off the cover.
5. Slide the cover off of the frame.

Figure 2 Outer Cover Removal

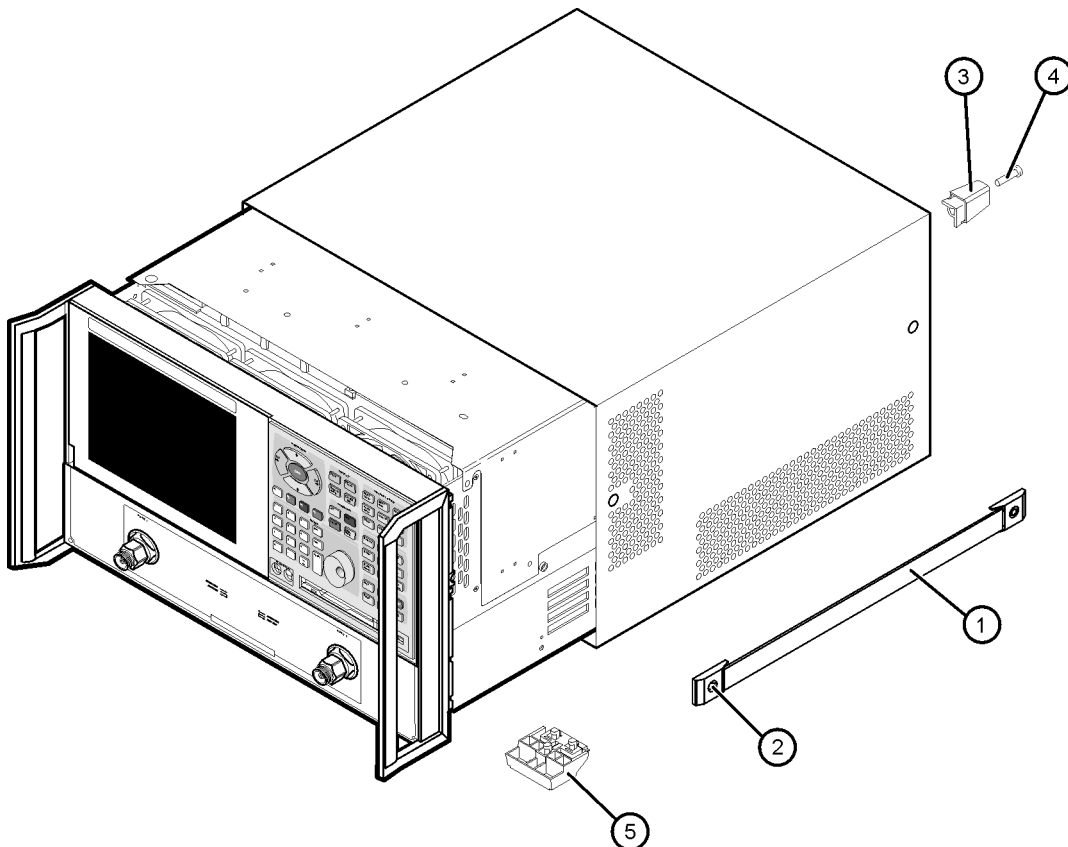

dt501a

Step 2. Remove the Front Panel Assembly (Option 014 Only)

Refer to [Figure 3](#) for this procedure.

1. With a 5/16-inch wrench, remove the six front panel semirigid jumper cables (item ①).
2. With a T-10 TORX driver, remove the eight screws (item ②) from the sides of the frame.

CAUTION Before removing the front panel from the analyzer, lift and support the front of the analyzer chassis.

3. Slide the front panel over the test port connectors.
4. Disconnect the front panel interface ribbon cable (item ③) from the A3 front panel interface board. The front panel is now free from the analyzer.

Figure 3 Front Panel Assembly Removal

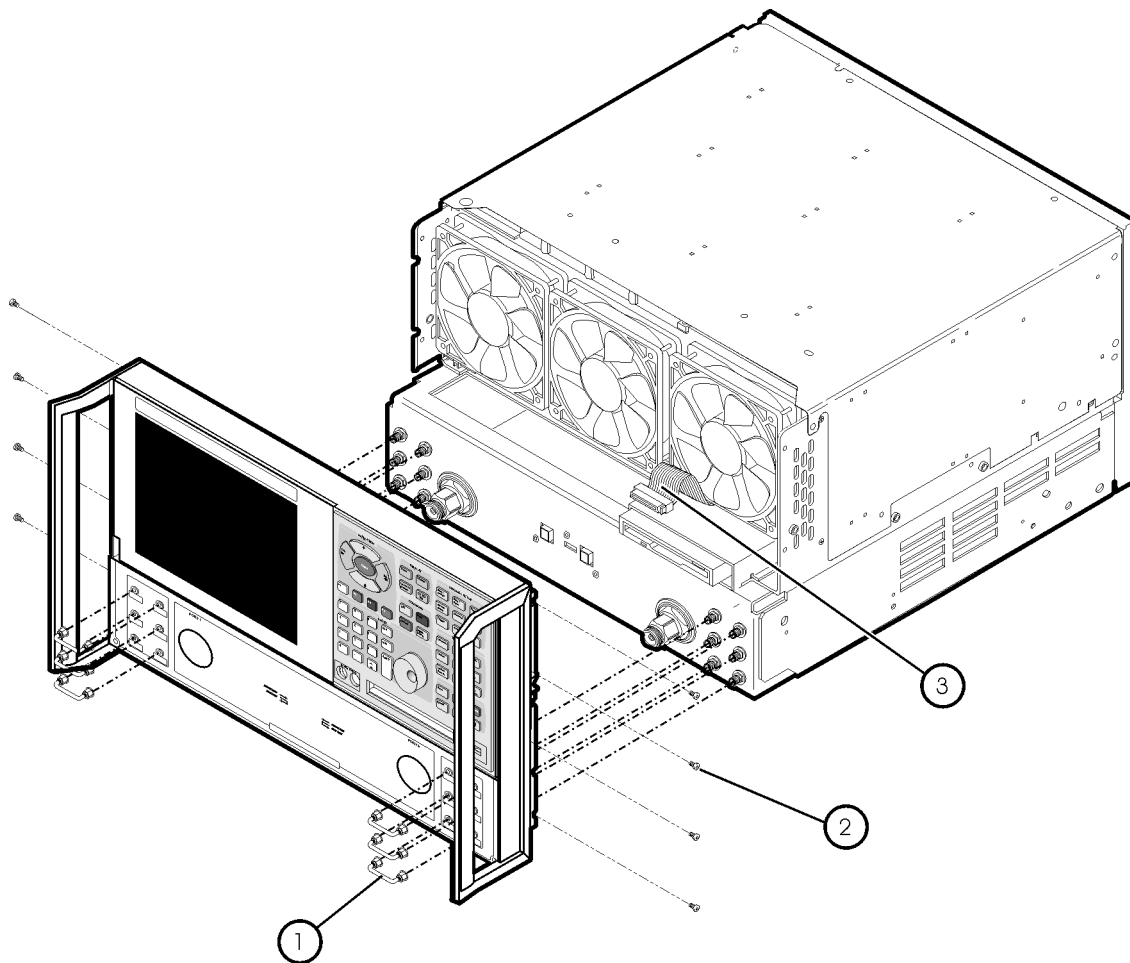

st536a

Step 3. Raise the Receiver Deck

Refer to [Figure 4](#) for this procedure.

1. Place the analyzer bottom-side up on a flat surface.
2. With a T-10 TORX driver, remove the four screws, (item ①), that secure the receiver deck.
3. Pull the latch pin (item ②) towards the center of the analyzer to release the receiver deck.
4. Lift the receiver deck to partially raise it, then release the latch pin (item ②). Lift the receiver deck to its fully raised position and ensure that the latch pin latches in the raised position.

Figure 4 Receiver Deck, Raising

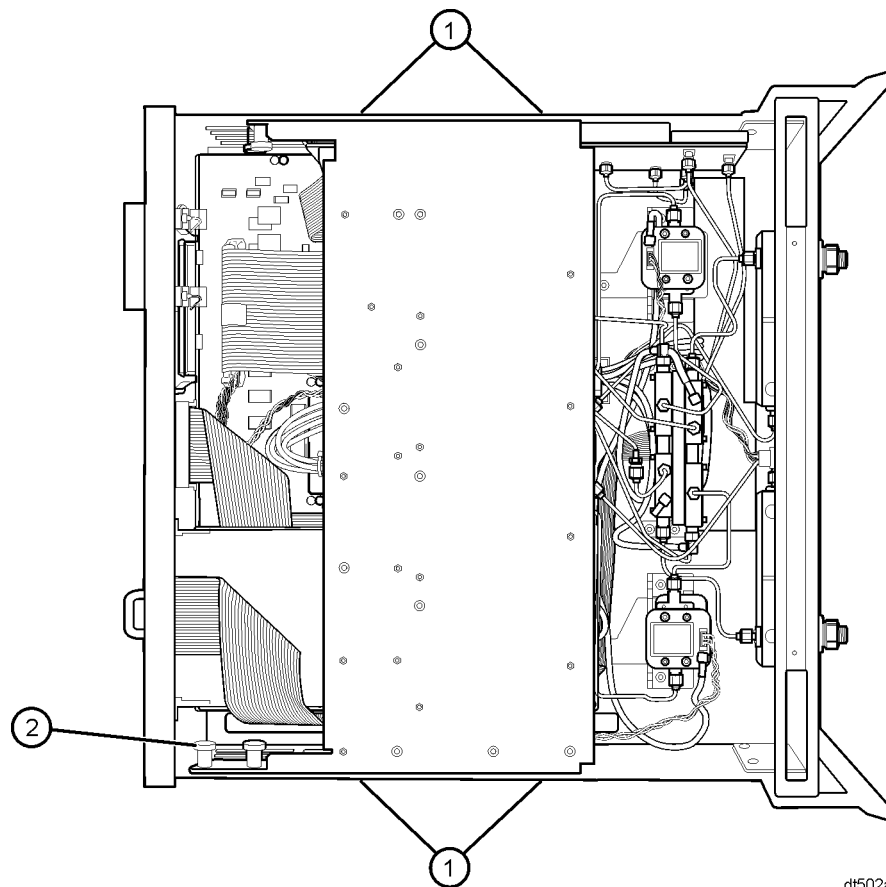

Step 4. Remove the Existing Cables

Analyzers WITH Option UNL but WITHOUT Option 014

Refer to [Figure 5](#) for the following procedure.

Remove the following cables:

- W7 E8364-20174 Channel R1 detector to A28 channel R1 mixer
- W8 E8364-20175 Channel R2 detector to A29 channel R2 mixer
- W9 E8364-20019 A25 test port 1 coupler to A27 channel A mixer
- W10 E8364-20020 A26 test port 2 coupler to A30 channel B mixer

Figure 5 Cable Removal, Analyzers with Option UNL but without Option 014

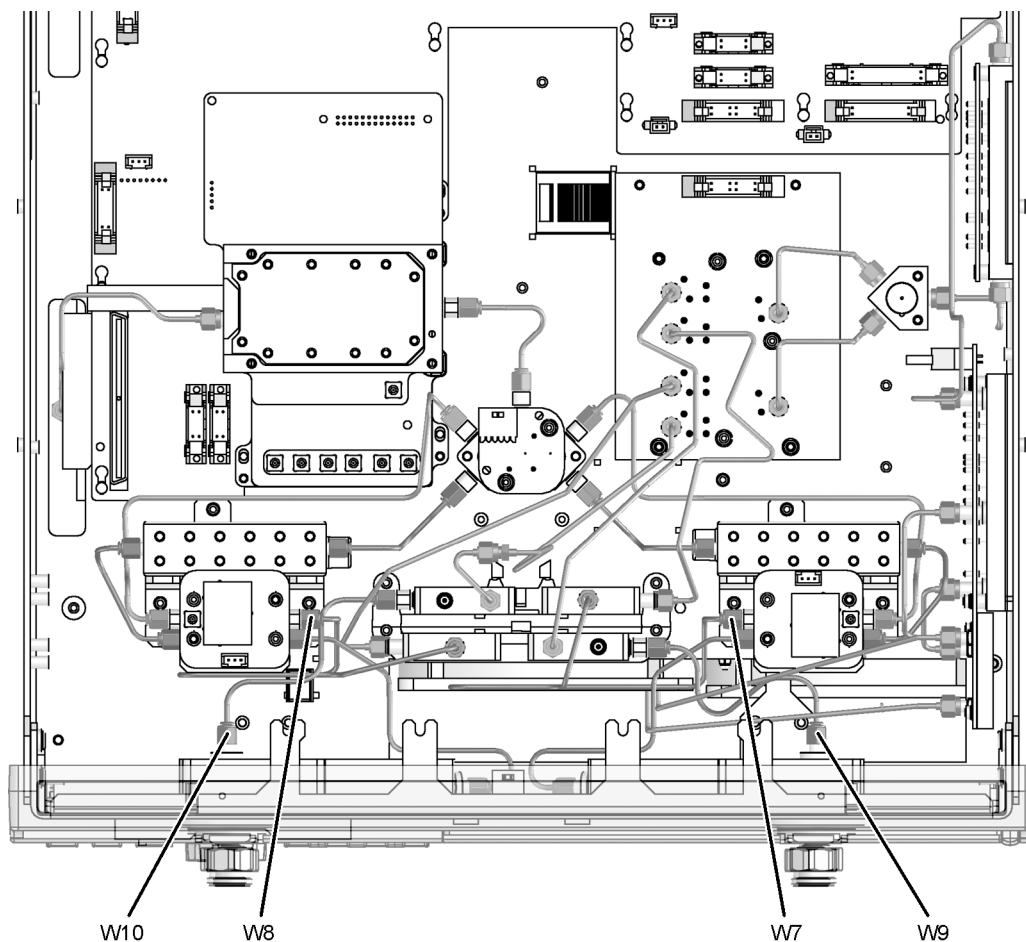

8364_020_01

Analyzers WITH Options UNL and 014 but WITHOUT Option 081

Refer to [Figure 6](#) for the following procedure.

Remove the following cables:

- W69 E8364-20045 PORT 1 RCVR A IN to A27 channel A mixer
- W72 E8364-20046 PORT 2 RCVR B IN to A30 channel B mixer
- W71 E8364-20177 REFERENCE 2 RCVR R2 IN to A29 channel R2 mixer
- W70 E8364-20176 REFERENCE 1 RCVR R1 IN to A28 channel R1 mixer

Figure 6 Cable Removal, Analyzers with Options UNL and 014 but without Option 081

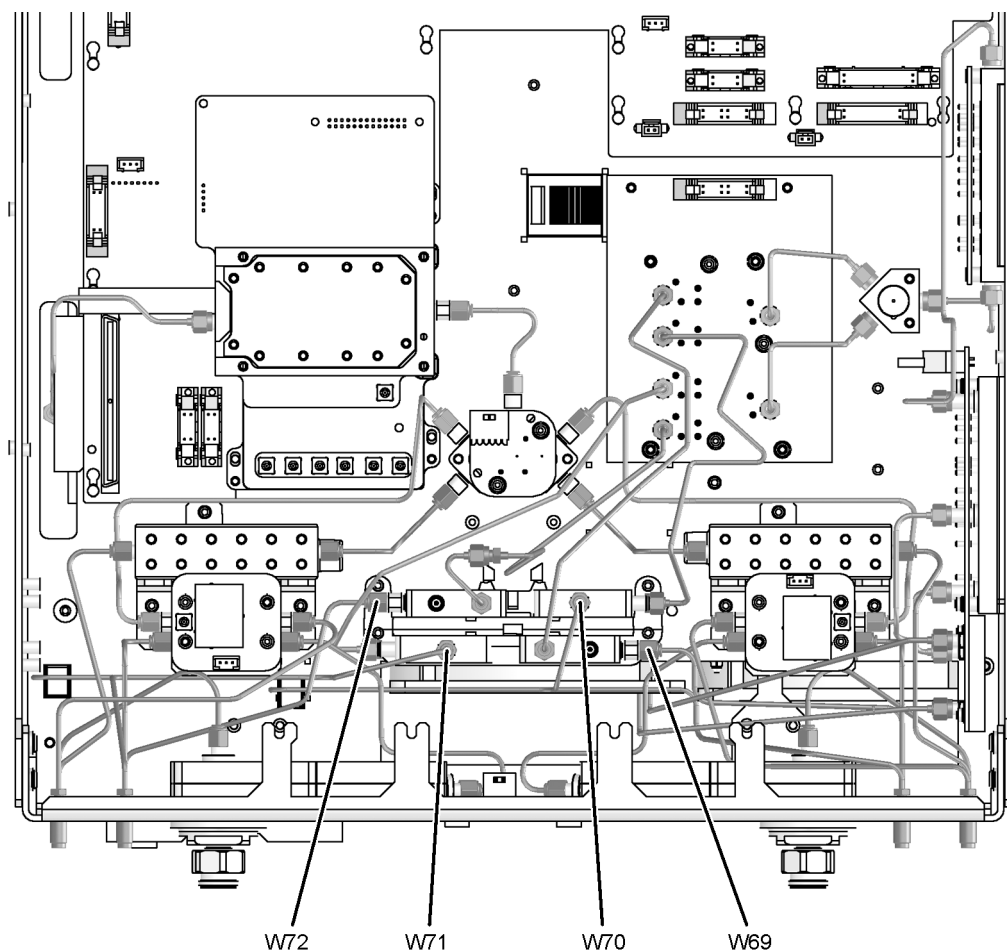

8364_020_02

Analyzers WITH Options UNL, 014, AND 081

Refer to [Figure 7](#) for the following procedure.

Remove the following cables:

- W69 E8364-20045 PORT 1 RCVR A IN to A27 channel A mixer
- W72 E8364-20046 PORT 2 RCVR B IN to A30 channel B mixer
- W71 E8364-20155 REFERENCE 2 RCVR R2 IN to A29 channel R2 mixer
- W99 E8364-20154 A45 reference switch to A28 channel R1 mixer

Figure 7 Cable Removal, Analyzers with Options UNL, 014, and 081

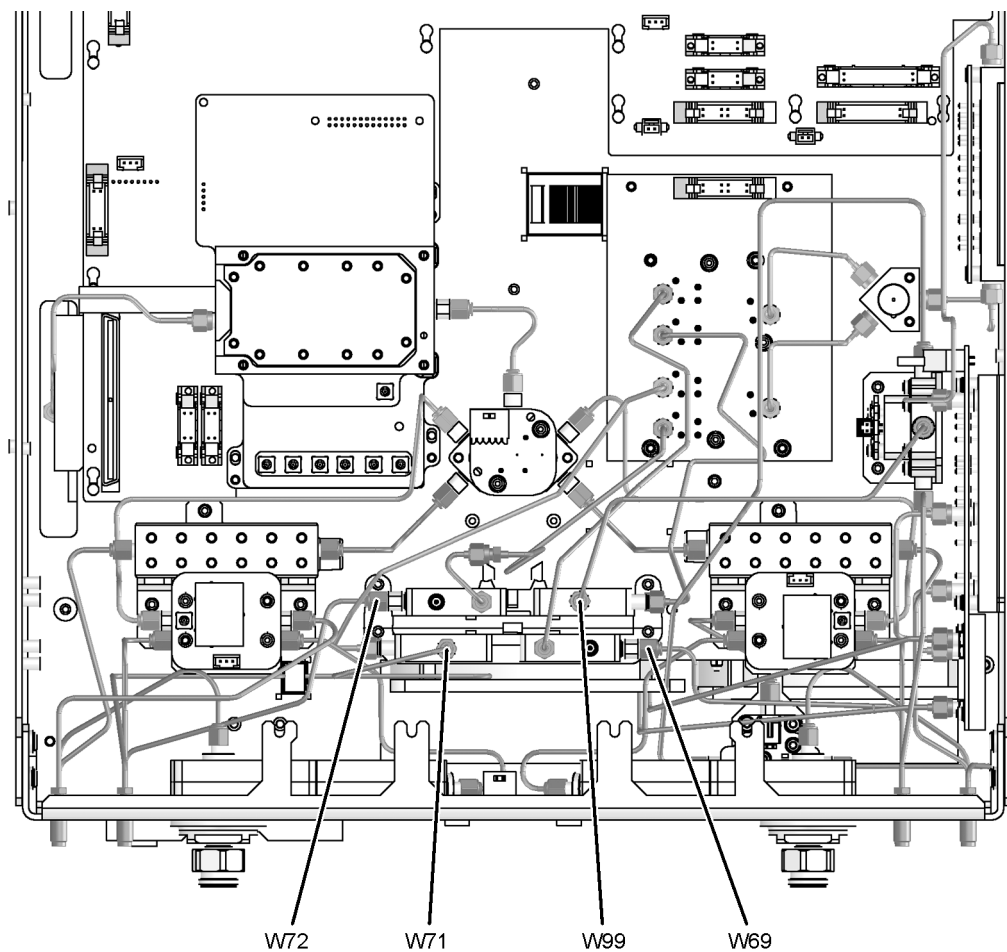

8364_020_03

Step 5. Install the Attenuators

Refer to [Figure 8](#) for the following procedure.

- Attach one step attenuator to each bracket, as shown, using two M3.0 x 8 screws (provided) for each.

Be careful to position the step attenuators so that the necessary cables can be attached. The end of the step attenuator with the ribbon cable connector must face toward the outside of the analyzer. Review the cable connections in [Figure 8](#) if necessary.

Figure 8 Attenuator Installation

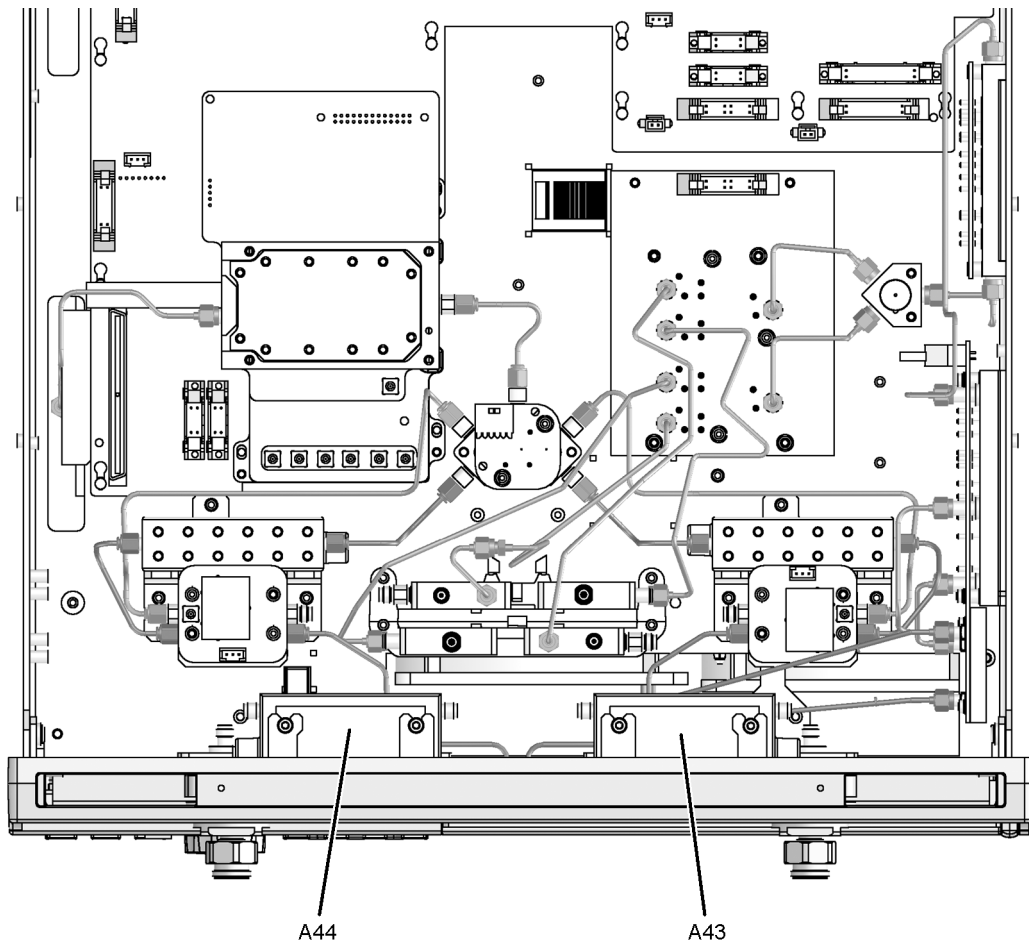

8364_020_04

Step 6. Install the Option 016 Cables

Analyzers WITH Option UNL but WITHOUT Option 014

Refer to [Figure 9](#) for the following procedure. The new parts referenced in this procedure are listed in [Table 1 on page 4](#).

Install the following cables in the order listed:

- Ribbon cable ① 8121-0819 A43 ch A attenuator to A16 motherboard (P1 RCVR ATT)
- Ribbon cable ② 8121-0819 A44 ch B attenuator to A16 motherboard (P2 RCVR ATT)
- W47 E8364-20131 A43 channel A step attenuator to A27 channel A mixer
- W48 E8364-20132 A44 channel B step attenuator to A30 channel B mixer
- W8 E8364-20150 Channel R2 detector to A29 channel R2 mixer
- W7 E8364-20149 Channel R1 detector to A28 channel R1 mixer
- W46 E8364-20148 A26 test port 2 coupler to A43 channel A step attenuator
- W45 E8364-20147 A25 test port 1 coupler to A44 channel B step attenuator

Figure 9 Cable Installation, Analyzers with Option UNL but without Option 014

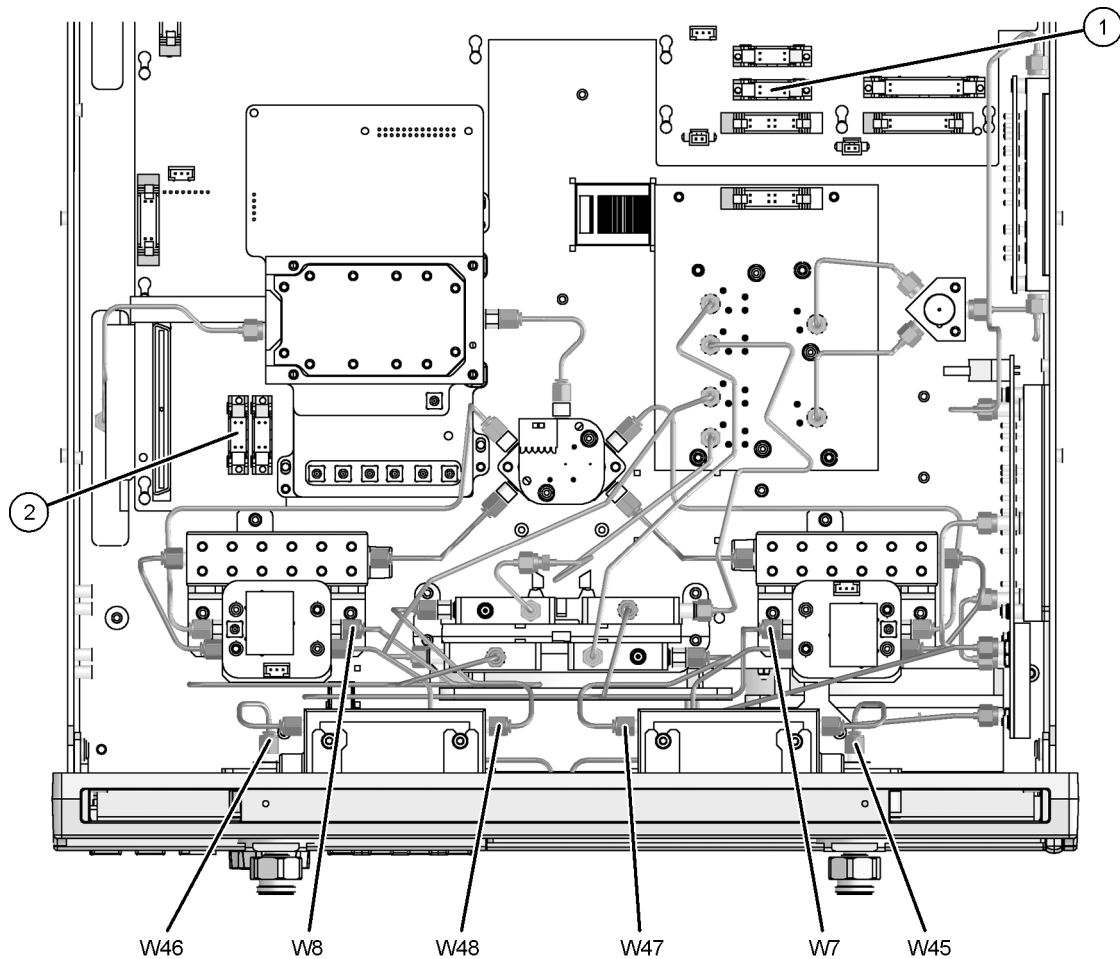

8364_020_05

Analyzers WITH Options UNL and 014 but WITHOUT Option 081

Refer to [Figure 10](#) for the following procedure. The new parts referenced in this procedure are listed in [Table 1 on page 4](#).

Install the following cables in the order listed:

- Ribbon cable ① 8121-0819 A43 ch A attenuator to A16 motherboard (P1 RCVR ATT)
- Ribbon cable ② 8121-0819 A44 ch B attenuator to A16 motherboard (P2 RCVR ATT)
- W47 E8364-20131 A43 channel A step attenuator to A27 channel A mixer
- W48 E8364-20132 A44 channel B step attenuator to A30 channel B mixer
- W71 E8364-20126 REFERENCE 1 RCVR R2 IN to A29 channel R2 mixer
- W70 E8364-20151 REFERENCE 2 RCVR R1 IN to A28 channel R1 mixer
- W50 E8364-20130 PORT 2 RCVR B IN to A44 channel B step attenuator
- W49 E8364-20129 PORT 1 RCVR A IN to A43 channel A step attenuator

Figure 10 Cable Installation, Analyzers with Options UNL and 014 but without Option 081

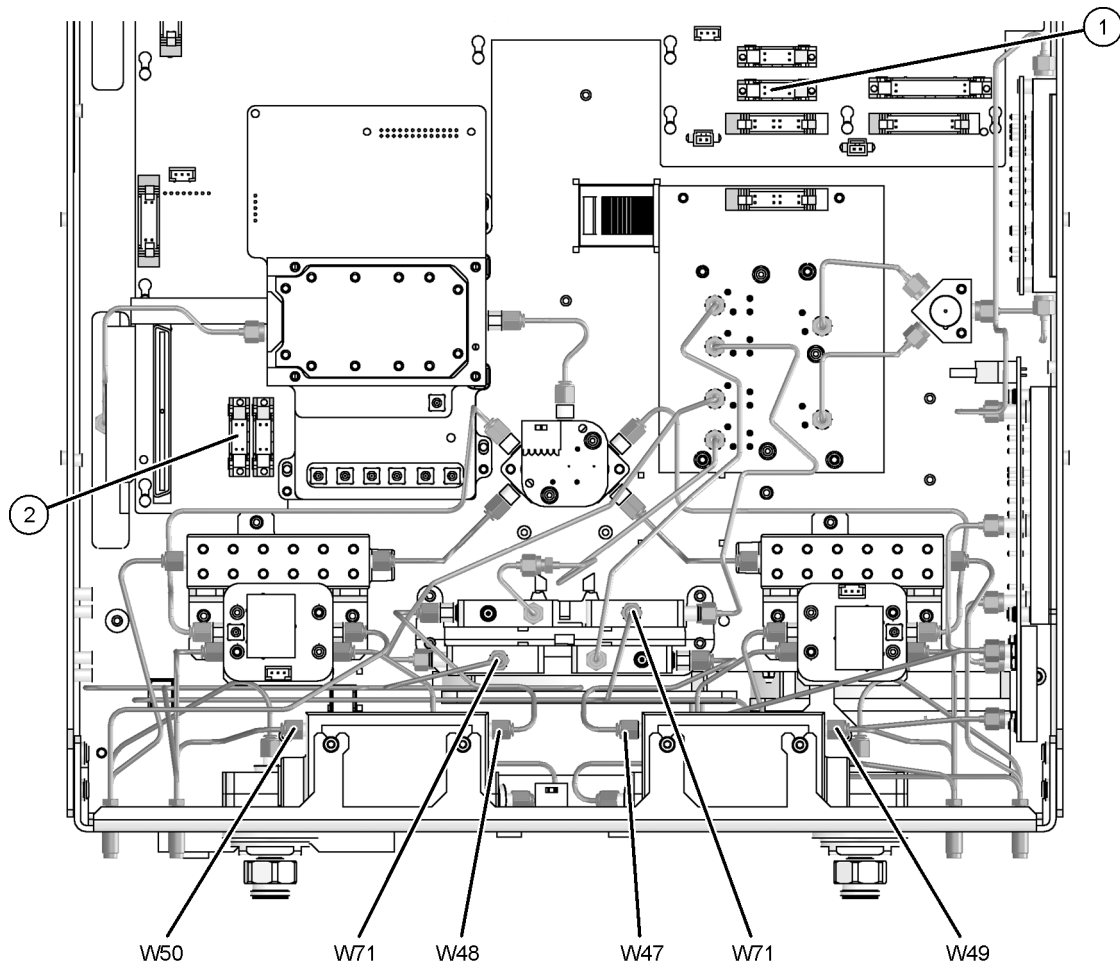

8364_020_06

Analyzers WITH Options UNL, 014, AND 081

Refer to [Figure 11](#) for the following procedure. The new parts referenced in this procedure are listed in [Table 1 on page 4](#).

Install the following cables in the order listed:

- Ribbon cable ① 8121-0819 A43 ch A attenuator to A16 motherboard (P1 RCVR ATT)
- Ribbon cable ② 8121-0819 A44 ch B attenuator to A16 motherboard (P2 RCVR ATT)
- W47 E8364-20131 A43 channel A step attenuator to A27 channel A mixer
- W48 E8364-20132 A44 channel B step attenuator to A30 channel B mixer
- W71 E8364-20126 REFERENCE 1 RCVR R2 IN to A29 channel R2 mixer
- W99 E8364-20125 A45 reference switch to A28 channel R1 mixer
- W50 E8364-20130 PORT 2 RCVR B IN to A44 channel B step attenuator
- W49 E8364-20129 PORT 1 RCVR A IN to A43 channel A step attenuator

Figure 11 Cable Installation, Analyzers with Options UNL, 014, and 081

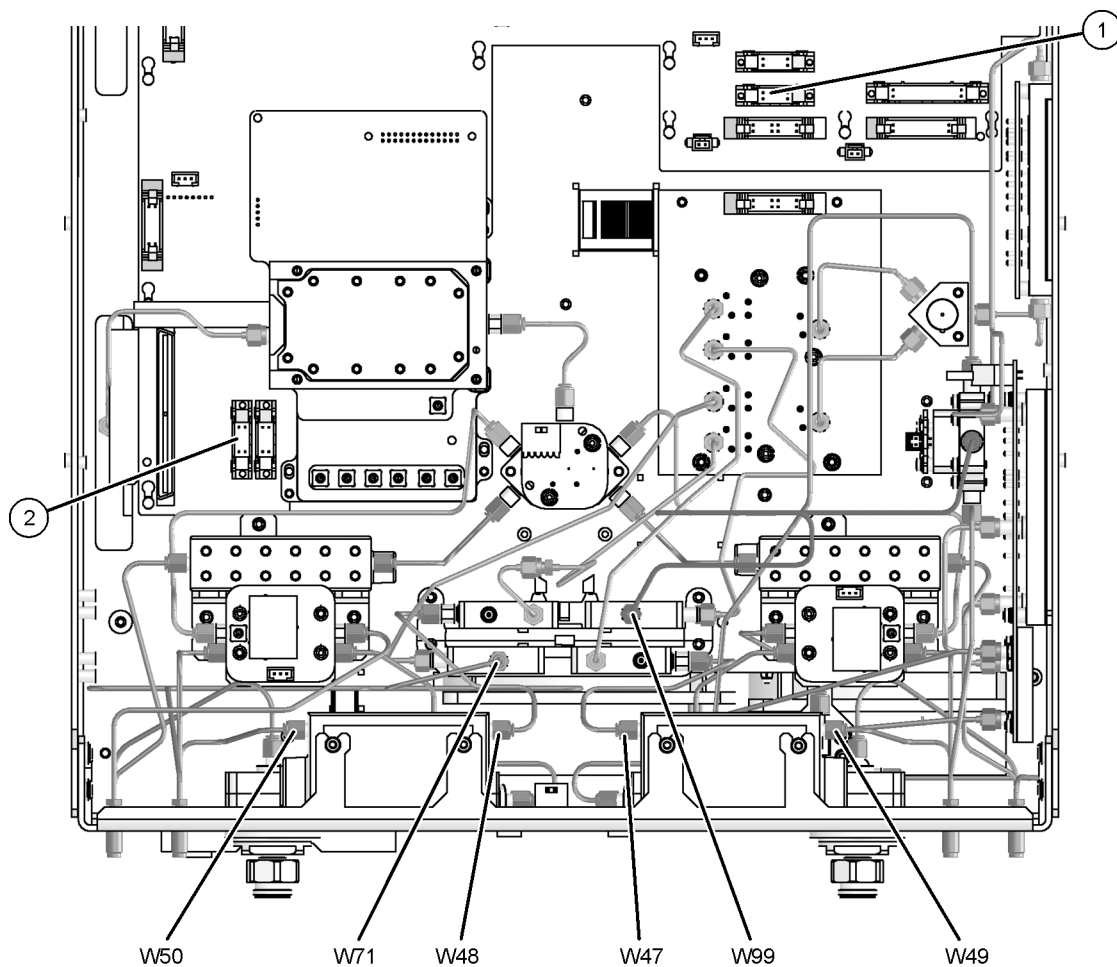

8364_020_07

Step 7. Lower and Fasten the Receiver Deck

Refer to [Figure 12](#) for this procedure.

1. Pull the latch pin (item ②) toward the center of the analyzer to release the receiver deck.
2. Lift the receiver deck to partially lower it, then release the latch pin (item ②). Lower the receiver deck to its fully lowered position and ensure that the latch pin latches in the lowered position.
3. With a T-10 TORX driver, install the four screws (item ①) to secure the receiver deck.

Figure 12 Receiver Deck, Lowering

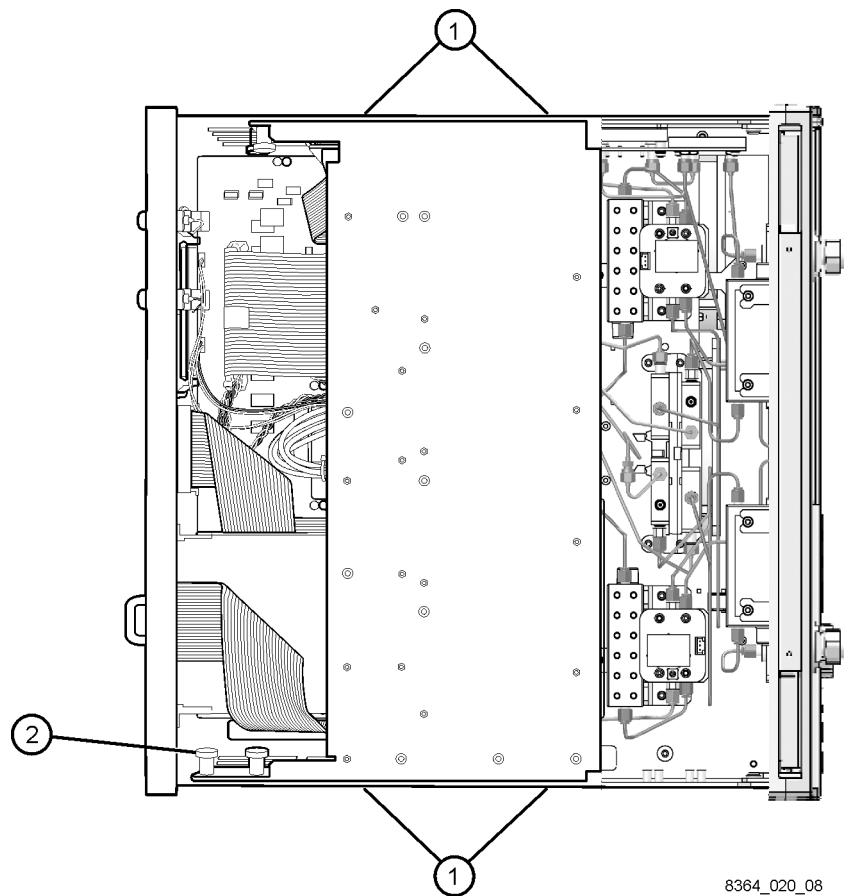

Step 8. Replace the Lower Front Panel Overlay (Option 014 Only)

NOTE The new parts referenced in this procedure are listed in [Table 1 on page 4](#).

Refer to [Figure 13](#) for this procedure.

1. From the back side of the front panel, use a blunt object in one of the cutouts in the frame to push the overlay (item ①) and separate it from the front panel.
2. From the front side of the front panel, pull the overlay completely off and discard it.
3. Remove any adhesive remaining on the front panel.
4. Remove the protective backing from the new Option 014 front panel overlay (item ①).
5. Starting from either the left or right side, *loosely* place the overlay in the recess on the lower front panel, ensuring that it fits tightly against the recess edges.
6. Once the overlay is in place, press it firmly onto the frame to secure it.

Figure 13 Lower Front Panel Overlay Replacement

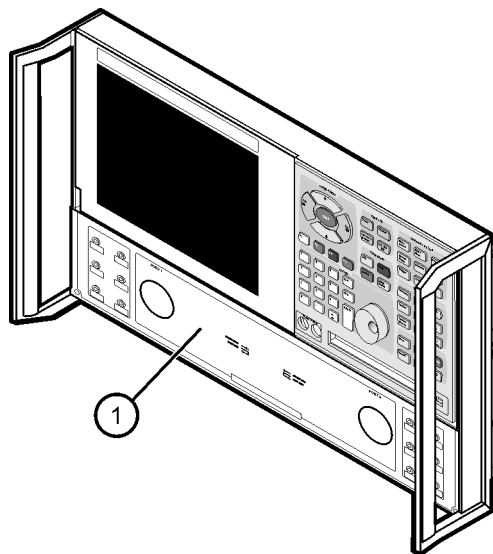

dt510a

Step 9. Reinstall the Front Panel Assembly and Front Panel Jumpers (Option 014 Only)

CAUTION Before installing the front panel assembly onto the analyzer, lift and support the front of the analyzer chassis.

Refer to [Figure 14](#) for this procedure.

1. Tighten all 12 of the front-panel feed-through connectors using a 5/16-inch torque wrench set to 21-in lbs.
2. Reconnect the ribbon cable (item ①) to the A3 front panel interface board.
3. Slide the front panel over the test port connectors being careful to align the power switch and floppy disk drive to their corresponding front panel cutouts. Ensure that the ribbon cable ① is located below the fan to prevent it from being damaged by the fan blades.
4. With a T-10 TORX driver, install the eight screws (item ②) in the sides of the frame.
5. Install the six semirigid jumpers (item ③) on the front panel and tighten to 10-in lbs.

Figure 14 Front Panel Assembly Reinstallation

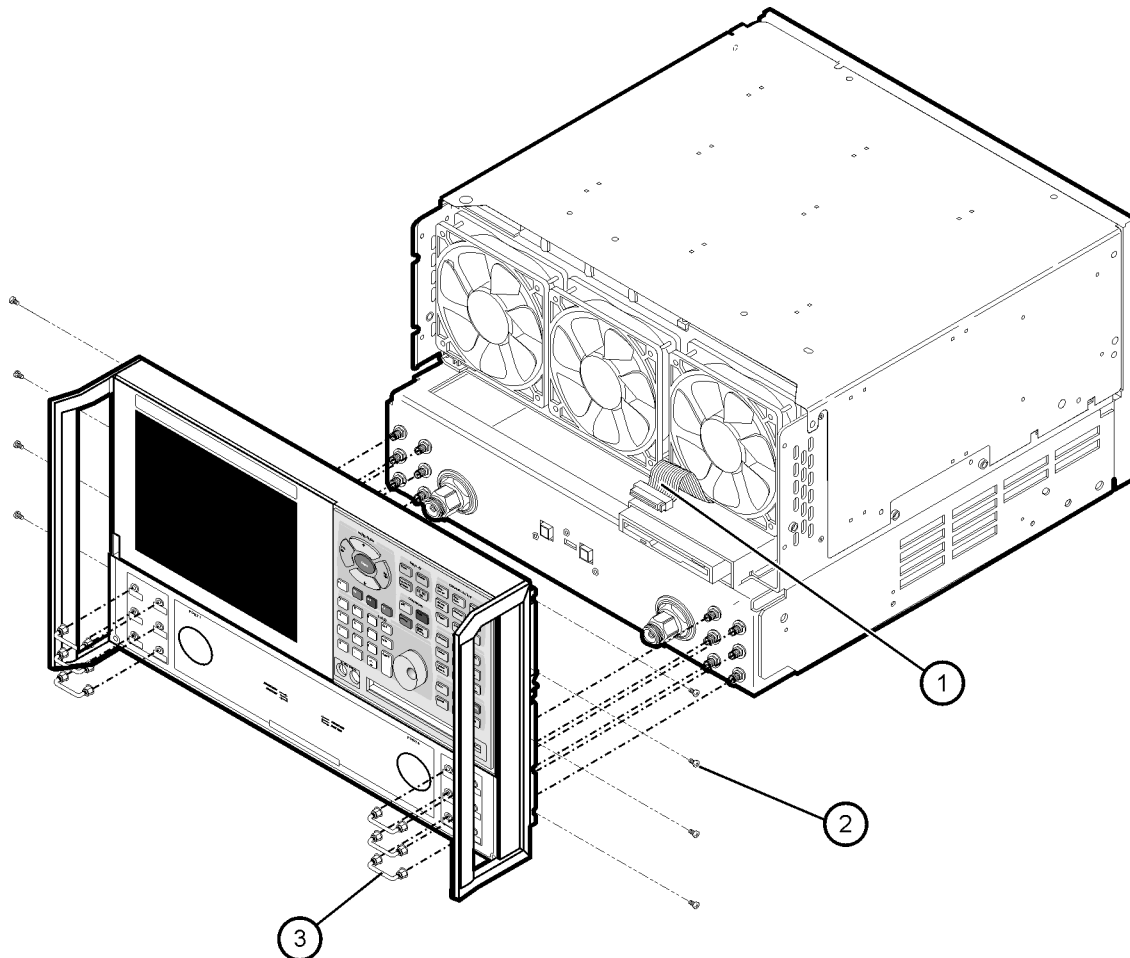

dt511a

Step 10. Reinstall the Outer Cover

CAUTION This procedure is best performed with the analyzer resting on its front handles in the vertical position. *Do not place the analyzer on its front panel without the handles.* This will damage the front panel assemblies.

Refer to [Figure 15](#) for this procedure.

1. Slide the cover over the analyzer frame.
2. With a T-20 TORX driver, install the four rear panel feet (item ①) by installing the center screws (item ②).
3. Slide the four bottom feet (item ③) into position on the cover.
4. With a T-20 TORX driver, install the strap handles (item ④) by installing the screws (item ⑤) on both ends of the handle.

Figure 15 Outer Cover Reinstallation

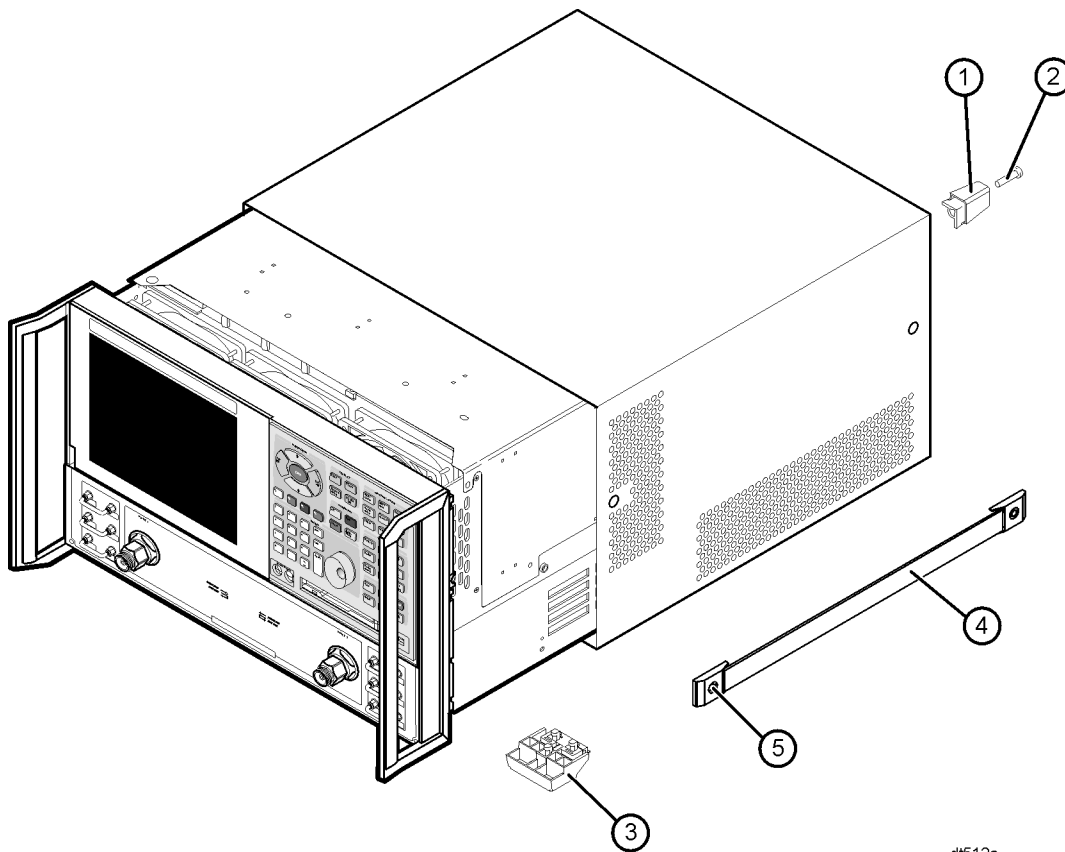

dt512a

Step 11. Enable Option 016

Procedure Requirements

- The analyzer must be powered up and operating to perform this procedure.
- The Network Analyzer program must be running.
- A mouse is recommended for this procedure but is not required.

Mouse Procedure

1. On the analyzer's **System** menu, point to **Service**, and then click **Option Enable**.
2. In the **Select Desired Option** list, click **016 - Receiver Attenuators**.
3. Click **Install**.
4. Click **Yes** in answer to the displayed question in the **Restart Analyzer?** box.
5. When the installation is complete, click **Exit**.

Front Panel Keys Procedure

1. In the **COMMAND** block, press **Menu/Dialog**.
2. In the **NAVIGATION** block, press the Right Tab and Arrows to move over to the **System** menu and down to the **Service** selection. Press the Right Tab to display the extended menu and the Arrows to select **Option Enable**. Press **Click**.
3. Tab to the **Select Desired Option** list, and press Arrows to select **016 - Receiver Attenuators**.
4. Tab to **Install**, and then press **Click**.
5. Click **Yes** in answer to the displayed question in the **Restart Analyzer?** box.
6. When the installation is complete, in the **COMMAND** block, press **OK** (or tab to **OK**, and then press **Click**).

Step 12. Verify that Option 016 Is Enabled

Procedure Requirements

- The analyzer must be powered up and operating to perform this procedure.
- The Network Analyzer program must be running.
- A mouse is recommended for this procedure but is not required.

Mouse Procedure

1. On the analyzer's **Help** menu, click **About Network Analyzer**.
2. Verify that "016" is listed after "Options:" in the display. Click **OK**.

NOTE If Option 016 has not been enabled, perform step 11 again. If the option is still not enabled, contact Agilent Technologies. Refer to ["Getting Assistance from Agilent" on page 2](#).

Front Panel Keys Procedure

1. In the **COMMAND** block, press **Menu/Dialog**.
2. In the **NAVIGATION** block, press the Right Tab and Arrows to move over to the **Help** menu, and down to the **About Network Analyzer** selection. Press **Click**.
3. Verify that "016" is listed after "Options:" in the display. In the **COMMAND** block, press **OK** (or tab to **OK**, and then press **Click**).

NOTE If Option 016 has not been enabled, perform step 11 again. If the option is still not enabled, contact Agilent Technologies. Refer to ["Getting Assistance from Agilent" on page 2](#).
